

## Product Description

The LR24 is a revolutionary architectural lay-in designed for applications that require high ambient light levels, including offices, schools, and hospitals. It utilizes Cree LED Lighting technology that generates white light with LEDs in a new way and is the first to combine high efficacy, beautiful color and affordability.

The use of this technology releases the design constraints of traditional lay-ins and enables a fresh approach to the architectural appearance of the light. It also allows an optimal distribution of light that delivers high illuminance levels to horizontal surfaces balanced with an ideal amount of light to vertical surfaces resulting in an effective, attractive, and comfortable environment.

Delivered light output is set to provide the ideal amount of light in high ceiling installations.

## Performance Summary

- Utilizes Cree TrueWhite™ technology
- CRI = 90
- 3500K
- Dimmable to 5% with 0-10V DC control
- 3800 lumens
- Nominal input power = 52 Watts
- Three Year Warranty

## Ordering Information

LR24-38SKA35 - 120V-277V, 3800 lumens, 3500K

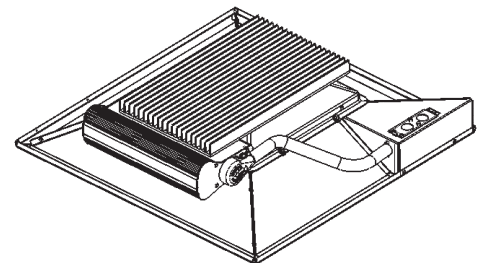
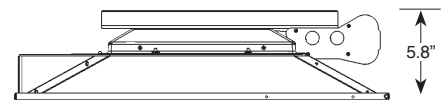
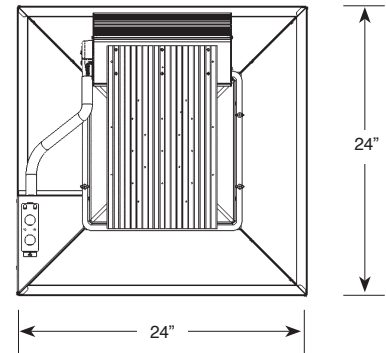

**WATTWORKS**

1078 Goodale Blvd. Columbus, OH 43212  
614-458-1162 [www.wattworks.com](http://www.wattworks.com)

**CREE**  
TRUE WHITE  
TECHNOLOGY

**CREE**  
LED Lighting

# LR24

## High Ceiling Architectural Lay-In

### Product Information

#### Cree TrueWhite™ Technology

- A better way to generate white light that utilizes a patented mixture of unsaturated yellow and saturated red LEDs.
- Tuned to optimal color point before shipment.
- Color management system maintains color consistency over time and temperature.
- Designed to last 50,000 hours and maintain at least 70% of initial lumen output.

#### Construction

- Cold rolled steel lower reflector for installation in nominal 2' x 2' ceiling openings.
- Field replaceable light engine integrates LEDs, driver, power supply, thermal management, and optical mixing components. Access to light engine from adjoining ceiling tiles.
- Integrated thermal management system conducts heat away from LEDs and transfers it to the surrounding environment. Designed to keep LEDs below specified maximum temperatures in typical commercial installations.
- Height = 5.8"

#### Optical System

- Proprietary optical system utilizes a unique combination of reflective and refractive optical components to achieve a uniform, comfortable appearance. Pixelation and direct view of uncomfortable LEDs is eliminated.
- Lower reflector finished with a textured high reflectance white polyester powder coating to create a comfortable visual transition from the diffuser to the ceiling plane.
- Mechanical shielding of diffuser delivers a subtle glowing appearance at high angles for visual integration with the ceiling plane.
- Distribution of light balances the delivery of high light levels to horizontal surfaces with an ideal amount of light to vertical surfaces.

#### Electrical System

- Integral, high efficiency driver and power supply
- Nominal power factor = 0.9
- Input voltage = 120V - 277V, 50/60Hz
- Dimmable to 5% with 0 to 10V DC control protocol

#### Regulatory and Voluntary Programs

- Tested and certified to UL standards

### Photometry

LR24-38SKA35 – Based on ITL Test 61450

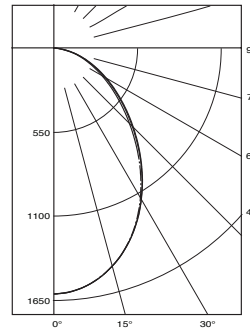

#### Intensity (Candlepower) Summary

ANGLE	CP0°	CP90°
0°	1900	1900
5°	1879	1881
15°	1742	1744
25°	1494	1500
35°	1165	1183
45°	825	856
55°	545	572
65°	328	349
75°	156	169
85°	2	6
90°	0	0

#### Zonal Lumen Summary

ZONE	LUMENS	%LAMP	%FIX
0° - 30°	1360	53.5	53.5
0° - 40°	2098	76.9	76.9
0° - 60°	3266	98.8	98.8
0° - 90°	3800	100.00	100.00

**WATTWORKS**

1078 Goodale Blvd. Columbus, OH 43212  
614-458-1162  www.wattworks.com

**CREE**   
LED Lighting

Cree LED Lighting

Morrisville • NC • 27560 • USA

1-919-287-7700 Fax 1-919-991-0730

www.CreeLEDLighting.com

© Copyright 2007-2009 Cree, Inc. All rights reserved. The information in this document is subject to change without notice.  
Cree LED Lighting, the Cree LED Lighting logo, TrueWhite, and the CreeTrueWhite Technology Logo are trademarks of Cree, Inc. LR24HCPI-07/2009